

TIME CONTROL

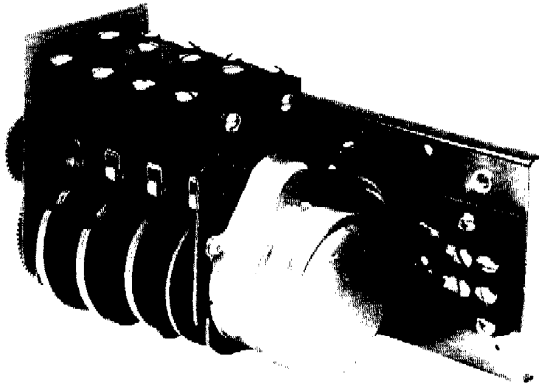

MP MULTIPULSE® SERIES REPEAT CYCLE TIMER



Closes and opens switches in a repeated sequence.

The MULTIPULSE® Repeat Cycle Timer consists of a synchronous motor driving a cam shaft through a gear train. The cam shaft rotates continuously as long as the motor is energized. Adjustable cams determine the point of closing and opening a switch during each cam shaft revolution.

The MULTIPULSE® is ideally suited to applications where operations occur in a predetermined sequence as in operating a series of dampers in a dust collecting system for periodic cleaning. The MULTIPULSE® may also be readily applied to single cycle applications as suggested on the back page of this bulletin.

FEATURES

- Available in three standard frame sizes — 4, 8, and 12 circuits.
- Synchronous motor insures positive repeatability.
- 21 standard time cycles available and over 250 time cycles available with selection of additional cycle gears.
- Closing and opening of each circuit independently adjustable.
- Expandex hubs.
- Compact

SPECIFICATIONS

Number of Circuits

1-12 Standard

Time Ranges

6 seconds to 36 hours, See Chart 1

Cam Setting Accuracy

1% of total cycle; (with special care - 1/2%)

Voltage/Frequency

120 V (+10, -15%), 50/60 Hz

240 V (+10, -15%), 50/60 Hz

The maximum starting, inrush and stalled currents must be limited to 30 amperes on the normally closed contacts and 15 amperes on the normally open circuits.

For 240 volts, limit currents to one half above values.

Output Rating

10 Amps, Resistive, 120 VAC

5 Amps, Resistive, 240 VAC

Repeat Accuracy

100% consistent to cam settings.

Laboratory Testing

U.L. Recognition E-61735

C.S.A. Certification LR-26861 

Eagle Signal Controls

A Division of Mark IV Industries, Inc.
8004 Cameron Road, Austin, Texas 78753 U.S.A.

TIME CONTROL



SELECTION OF TIME RANGE

Prior to selection of the exact total time cycle, first determine the minimum and maximum time cycle most likely to be needed for your application. Select the time range which will include these time cycles by referring to the two left hand columns of Chart 1.

TO CHANGE CYCLE GEARS

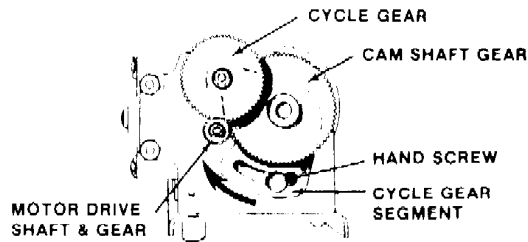

Figure 1

1. Select gear from Chart 1 to obtain correct time cycle.
2. Loosen the handscrew and move cycle gear segment upward (direction of arrow).
3. Remove cycle gear and install desired replacement.
4. Drop segment, meshing cycle gear with drive gear. Move cycle gear and gear segment slightly upward and tighten hand screw. This is important to insure a slight amount of backlash between gears to prevent possibility of a bind.

SELECTION OF TIME CYCLE

Timer is provided with MP5-48 cycle gear, and those time ranges (shaded in chart below) are standard. If time cycle other than standard is required, order additional cycle gear(s) to achieve desired timing.

CHART 1

TIME RANGE		TIME CYCLES AVAILABLE WITH DIFFERENT CYCLE GEARS												
CAT. SYM-BOL	RANGE	CYCLE GEAR CATALOG NUMBER												
		MP5-24	MP5-28	MP5-32	MP5-36	MP5-40	MP5-44	MP5-48	MP5-52	MP5-56	MP5-60	MP5-64	MP5-68	MP5-72
		NUMBER OF TEETH IN CYCLE GEAR												
		24	28	32	36	40	44	48	52	56	60	64	68	72
TIME IN SECONDS														
*01	6-18 Sec	6	7	8	9	10	11	12	13	14	15	16	17	18
02	12-36 Sec	12	14	16	18	20	22	24	26	28	30	32	34	36
03	15-45 Sec	15	17½	20	22½	25	27½	30	32½	35	37½	40	42½	45
04	18-54 Sec	18	21	24	27	30	33	36	39	42	45	48	51	54
05	20-60 Sec	20	23½	26½	30	33½	36½	40	43½	46½	50	53½	56½	60
07	30-90 Sec	30	35	40	45	50	55	60	65	70	75	80	85	90
08	36-108 Sec	36	42	48	54	60	66	72	78	84	90	96	102	108
09	60-180 Sec	60	70	80	90	100	110	120	130	140	150	160	170	180
11	90-270 Sec	90	105	120	135	150	165	180	195	210	225	240	255	270
TIME IN MINUTES														
13	2-6 Min	2	2½	2½	3	3½	3½	4	4½	4½	5	5½	5½	6
15	3-9 Min	3	3½	4	4½	5	5½	6	6½	7	7½	8	8½	9
17	6-18 Min	6	7	8	9	10	11	12	13	14	15	16	17	18
19	9-27 Min	9	10½	12	13½	15	16½	18	19½	21	22½	24	25½	27
20	12-36 Min	12	14	16	18	20	22	24	26	28	30	32	34	36
25	30-90 Min	30	35	40	45	50	55	60	65	70	75	80	85	90
27	60-180 Min	60	70	80	90	100	110	120	130	140	150	160	170	180
TIME IN HOURS														
29	1.5-4.5 Hrs	1½	1¾	2	2¼	2½	2¾	3	3¼	3½	3¾	4	4¼	4½
31	6-18 Hrs	6	7	8	9	10	11	12	13	14	15	16	17	18
32	12-36 Hrs	12	14	16	18	20	22	24	26	28	30	32	34	36

The total number of switches on a timer, the number of switches actuated simultaneously, and the total time cycle determine the load on the timer motor and gearing.

*The MULTIPULSE® with standard motors should not be used for time cycles faster than shown in next column. Heavy duty motor (07 Feature) required on "01" time range, 8 circuits or more.

With 4 switches — 10 second minimum cycle
 With 8 switches — 15 second minimum cycle
 With 12 switches — 20 second minimum cycle

NOTE: The above minimum cycles are based upon the cams being set so they do not raise more than 1.2 the switches simultaneously.

TIME CONTROL



ELECTRICAL DIAGRAM

When referring to timer switch numbers, count from right to left. Switch number 1 is on the right end adjacent to the timer motor.

Load circuits which are closed 50 to 97% of total cycle (over 180° rotation of cam shaft) must be connected to the NORMALLY OPEN side of the switch.

Load circuits which are closed 1% to 50% of total cycle (less than 180° rotation of cam shaft) must be connected to NORMALLY CLOSED side of the switch.

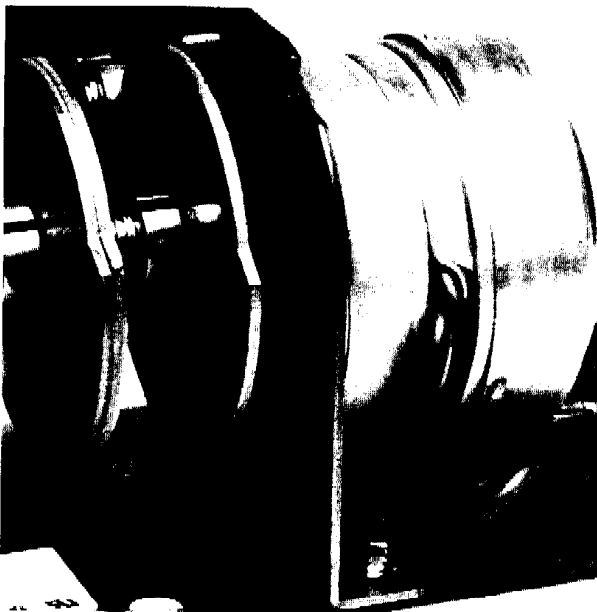

Figure 2

Switch #1 closes its NORMALLY OPEN side at "0" on dial. Use this as "0" reference point when making timing charts and setting cams.

CAM SETTINGS

From 1% to 98% closure adjustment is provided by adjusting the two adjacent cams in relation to each other and connecting to the NORMALLY OPEN or NORMALLY CLOSED side of the switch.

Settings can be easily made in the field. Loosen the two screws "A" just enough to allow the cam to slip. Raise "B" of the cam is set to raise the switch roller where the NORMALLY OPEN side is to close. Drop-off "C" is set to lower the switch roller where the NORMALLY CLOSED side is to close.

Tightening the screws expands the hub, locking the cam firmly.

To turn the cam shaft manually to facilitate setting the cams, loosen the hand screw and disengage the cycle gear (see Figure 1).

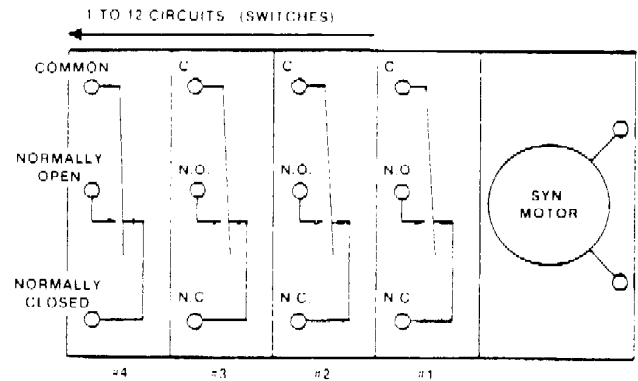

Figure 3

PERCENTAGE DIAL

The percentage dial calibrated to 100% in 2½ divisions indicates the cam shaft position.

The "0" point of the dial is fixed in relation to the #1 switch cam so that the NORMALLY OPEN side closes at "0". The other cam is adjustable for 50 to 97% closure.

The cams for all other switches are adjustable to any point on the percentage dial.

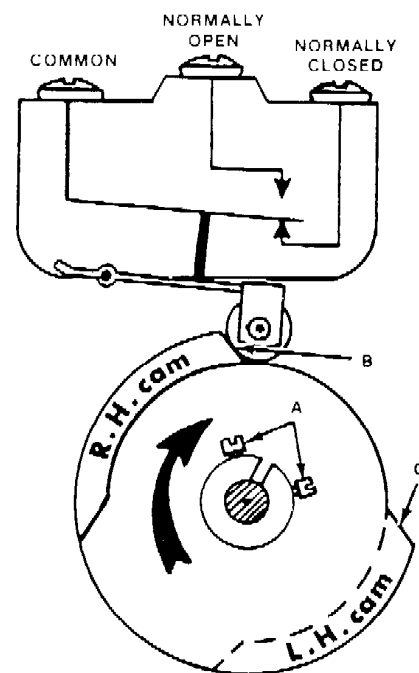

Figure 4

TIME CONTROL



ONE CYCLE OPERATION

Many applications require only one cycle of operation upon each actuation of the "start" switch. Eagle Bulletin 130 describes the MULTIFLEX Reset Timer and Bulletin 140 describes the POLYFLEX Reset Timer, both of which are available for those applications requiring an almost instantaneous (spring) return to the "0" position. The MULTIPULSE® can be used where spring return is not required and it is satisfactory to have the timer motor turn the cam shaft forward to "0". Typical circuits are illustrated below.

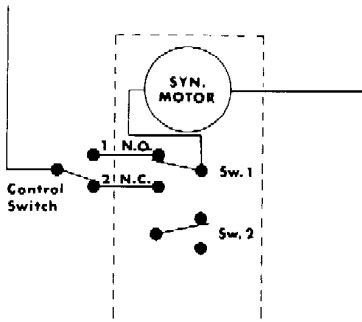

Figure 5

Control switch is moved to "1" to start timer. The timer switch opens at 300° and stops timer.

Return of control switch to position "2" restarts timer and advances it to "0".

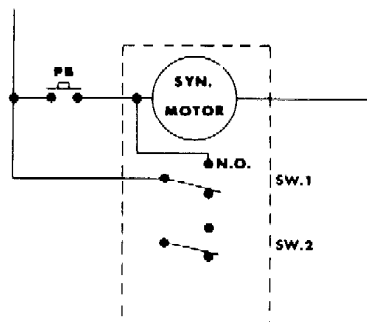

Figure 6

Pushbutton is held down until the cam shaft turns far enough to close switch #1. Then the motor keeps running to complete one revolution of the cam shaft.

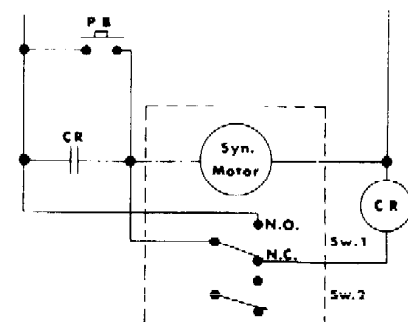
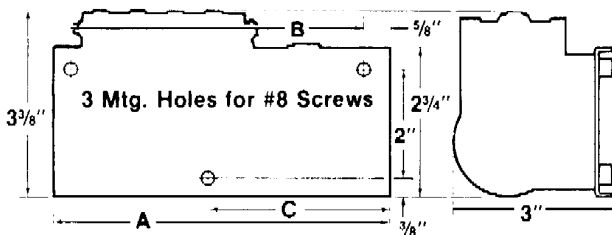

Figure 7

Momentary contact pushbutton "locks in" relay to start timer. During the ensuing cycle, the relay opens and timer switch #1 keeps the motor running for the balance of the cycle.

DIMENSIONS



FRAME SIZE				
Switches	Cat. No	A	B	C
2 to 4	MP2 to MP4	6 7/8"	5 1/2"	3 3/8"
5 to 8	MP5 to MP8	9 1/4"	8 3/8"	3 3/8"
9 to 12	MP9 to MP12	12 1/8"	11 1/4"	6 1/2"

ORDERING INFORMATION

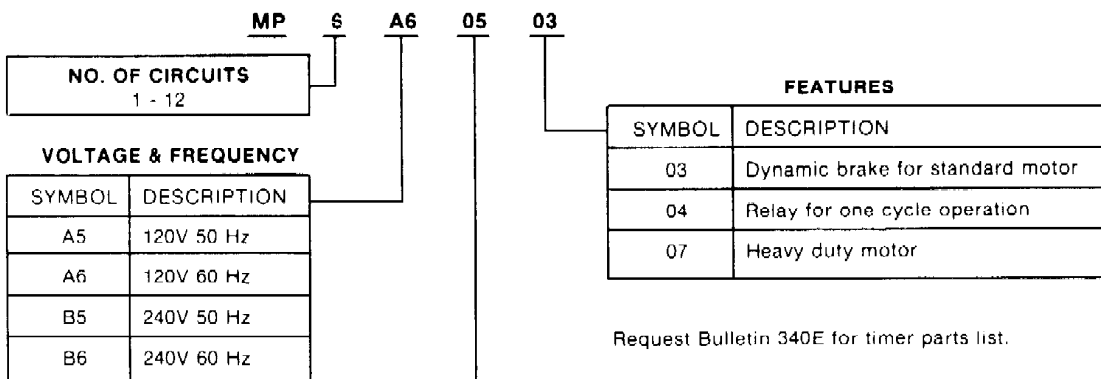

TIME RANGE — See Chart 1

Time cycles in shaded area (w/MP5-48 gear) are standard. Specify cycle gears for time cycles other than standard.

Request Bulletin 340E for timer parts list.