

## SPECIFICATIONS

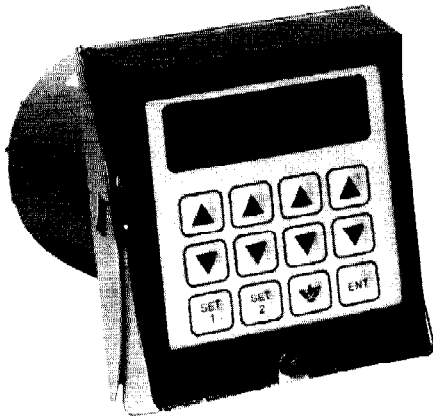

### Time Ranges

MAXIMUM RANGE	MINIMUM SETTING
199.99 Sec	.01 Sec
1999.9 Sec	.1 Sec
199 Min:59 Sec	1 Sec
199 Hr:59 Min	1 Min

### Operating Voltage & Frequency

SYMBOL	VOLTAGE & FREQUENCY
A6	120 VAC 50/60 Hz
B6	240 VAC 50/60 Hz

### Setting Accuracy

± 0.05% or 50ms, whichever is larger (0° to 60°C)

### Repeat Accuracy

± .001% or 35ms, whichever is larger (0° to 60°C).

### Reset Time

30 ms following voltage removal from simulated clutch input (CR1).

### Operating Temperature

+32° to +140°F (0° to 60°C)

### Operating Voltage/Frequency

SYMBOL	VOLTAGE & FREQUENCY
A6	120 VAC 50/60 Hz
B6	240 VAC 50/60 Hz

### Output Rating

Relay - 10 Amp (resistive) 120 VAC

Mechanical Life - 20 million operations

Electrical Life - contingent upon controlled load

### Vibration

Unit function is unaffected by 2.5G sinusoidal vibration magnitude in both directions of the perpendicular mounting axes imposed from 10 to 100 Hz.

### Static Discharge

Unit operation unaffected by a constant 3600 volt peak, 60 Hz discharge applied to the grounded front plate of the unit at a relative humidity of less than 25%.

### Battery Life

The CX uses a lithium battery with an expected life of 10 years.

### Power On Response Time

300 ms maximum after voltage applied to terminal 11.

### Laboratory Testing

U.L. Recognition E96337  
C.S.A. Certification LR26861



The CX100 timer is a solid state repeat cycle timer that will alternately turn an output on and off as long as power is applied to the unit. The CX100 timer is a microprocessor based timer with digital setting for greater setting accuracy than can be achieved with analog style repeat cycle timers. In addition to its greater setting accuracy, the CX100 timer is fully programmable to provide a number of time ranges and operating modes in one unit.

The ON and OFF time ranges for the CX100 timer are individually programmable for four time ranges from 199.99 seconds to 199 hours and 59 minutes. The CX100 timer is also programmable to have the ON time first instead of the OFF time first, and to reset or non-reset on power interruption. The time ranges and the operating characteristics of the unit are programmed using 7 miniature rocker switches located inside the unit housing.

The CX100 timer is housed in a standard CYCL-FLEX® enclosure. This plug-in enclosure is designed to allow easy timer removal for programming changes and service.

The time cycle is shown on a 0.5 inch high, 4½ digit (19999) liquid crystal display. Annunciators at the right hand side of the display indicate the operating mode. These annunciators flash to indicate when the timer is in the ON time cycle, and are constantly ON to indicate when the timer is in the OFF time cycle.

The CX100 timer has two socket mount 10 amp output relays. One set of relay contacts perform the ON/OFF cycle switching. The other relay is a set of instantaneous contacts that energize when power is applied to the start input of the unit, and do not deenergize until power is disconnected from the start input.

The CX100 timer includes a time inhibit input which allows the timing function to be stopped without resetting the unit.

## OUTPUT OPERATION

The CX100 timer has two sets of relay outputs. One set of contacts are instantaneous contacts that energize when power is applied to the start circuit. The instantaneous contacts remain energized until the unit is reset.

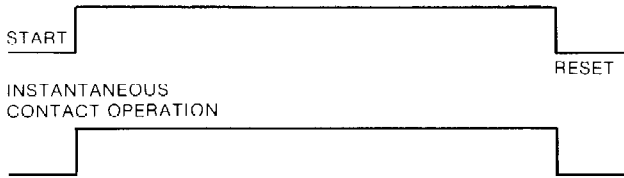

The other set of relay contacts provides the ON/OFF REPEAT CYCLE OPERATION. THE PROGRAMMING OF THE ON/OFF time first provides two operating modes for these programmed contacts.

### OFF Time First/Repeat Cycle Operation

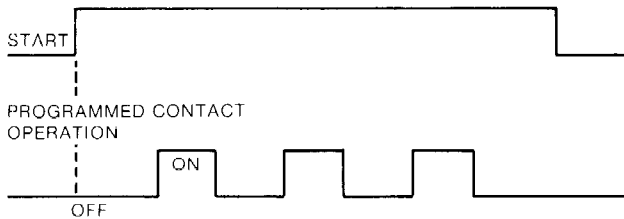

### ON Time First/Repeat Cycle Operation

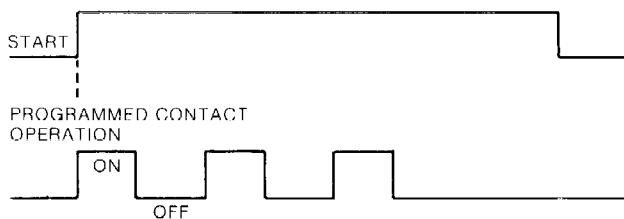

## RESET MODE

The CX100 Timer can be programmed to either reset or stop at its current position in the timing cycle if power is removed from the unit. With DIP switch 7 turned off, if the control switch to terminal 1 is opened, or if power is interrupted to terminal 11, the CX100 timer will reset to the beginning of the first time cycle. With switch 7 turned on, if power is removed from terminal 1 or 11, the CX100 timer will stop where it was in the timing cycle. The timing cycle

will begin again where it left off when power is reapplied to both terminals 1 and 11. Note that in the NON-RESET mode (switch 7 on), if power is removed from terminal 1 and 11 during the ON timing cycle, the output relays will be deenergized. When power is reapplied to terminal 11, the programmed relay will again be energized. The ON time period will be continued, and the instantaneous relay will again be energized when the control switch to terminal 1 is closed.

## OPERATION

### Programming Procedure

A series of 7 miniature rocker switches located inside the unit housing are used to program the time ranges and operating modes of the CX100 timer. The following table defines the switch conditions to program the operating parameters. **CAUTION: The product program label should always be marked to indicate the operating mode of the unit in case replacement is required.**

X = Switch ON O = Switch OFF Blank = Don't Care

SYM.	ON/OFF TIME FIRST	SWITCH NUMBER						
		1	2	3	4	5	6	7
1	ON Time First	X						
2	OFF Time First	O						
OFF TIME RANGE								
1	199.99 Sec		X	X				
2	1999.9 Sec		O	X				
3	199 Min:59 Sec			X	O			
4	199 Hr:59 Min			O	O			
ON TIME RANGE								
1	199.99 Sec				X	X		
2	1999.9 Sec				O	X		
3	199 Min:59 Sec				X	O		
4	199 Hr:59 Min				O	O		
BATTERY								
1	Battery ON							X
2	Battery OFF							O
RESET MODE								
1	Non-Reset on Power Fail							X
2	Reset on Power Fail							O

### Entering and Displaying Setpoints

When the CX100 unit is powered up for the first time, or after the battery has been cycled off and on, the digit display will show four hyphens. The unit will not operate until it has been provided with ON and OFF time setpoints, clearing the display of hyphens.

To create or change the OFF time setpoint, press the **SET1** key. The setpoint, if any, is displayed and the panel key pads become active. The operation of the timing function and the output loads are not affected. For setpoint changes, the SET indicator appears on the

graphics panel. The setpoint is changed by pressing appropriate  $\Delta$  or  $\nabla$  key pads. Pressing a  $\Delta$  key increments the setpoint digit located above the key; the  $\nabla$  key decrements the digit located above the key. If the key is continually depressed the digit will change every .5 second until the key is released. The display will carry to the digit on the left on the 9 to 0 transitions when using the  $\Delta$  keys. The display will borrow from the digits on the left on the 0 to 9 transitions when using the  $\nabla$  keys. On second and minute ranges, the display will carry on the 59 to 00 transition and borrow on the 00 to 59 transition of the two least significant digits.

When the desired setpoint is displayed, touch the **ENT** key. The new setpoint is entered, all  $\Delta$  and  $\nabla$  keys become inoperable and "SET" disappears from the graphics panel. New setpoints can be entered while the unit is timing or counting, but they will not take effect until the next reset.

To create or change the ON time setpoint press the **SET2** key. The ON time setpoint is changed by pressing the  $\Delta$  or  $\nabla$  keys as noted above. When the desired setpoint is displayed, press the **ENT** key.

The ON and OFF setpoints may be displayed at any time without disturbing the timing cycle by pressing **SET1** or **SET2**. The actual value is returned by pressing **ENT**.

## KEYPAD LOCK

A keypad "lock" is provided on the CX100 Timer to prevent unauthorized tampering. To initiate the keypad lock, press the Eagle Signal logo key for 10 seconds. To disable the lock to change setpoints, remove power from pin 11 and disconnect or turn the battery off. The unit will lose all setpoints and they must be re-entered for further operation.

## CX100 TERMINAL ASSIGNMENTS

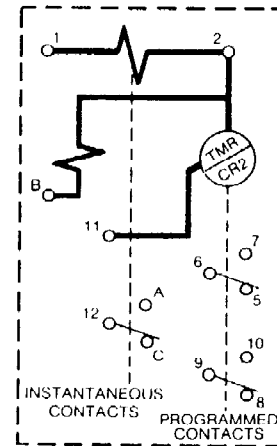

## WIRING DIAGRAMS — Bold Lines are Internal Wiring

Power to unit is applied to terminal 11 and 2. The unit is started by applying power to terminals 1 and 2. **Power must be applied to terminal 11 at least 300 milliseconds before power is applied to terminal 1.** An isolated input is provided on terminal B which functions as a time inhibit input. One set of instantaneous contacts is provided which transfer whenever terminal 1 is energized. In addition, two sets of programmed contacts are provided.

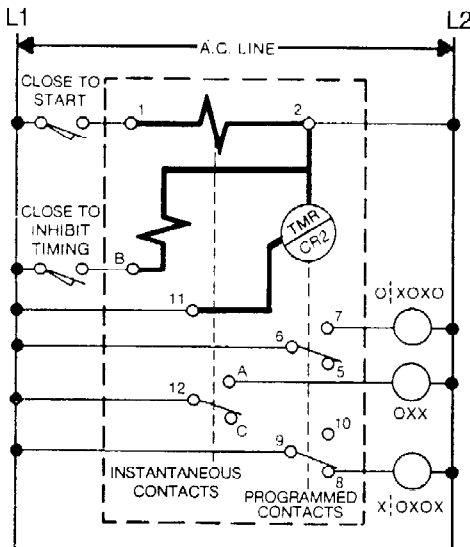

ON Time First - Close control switch to begin timing cycle. Programmed contacts transfer as soon as control input closes.

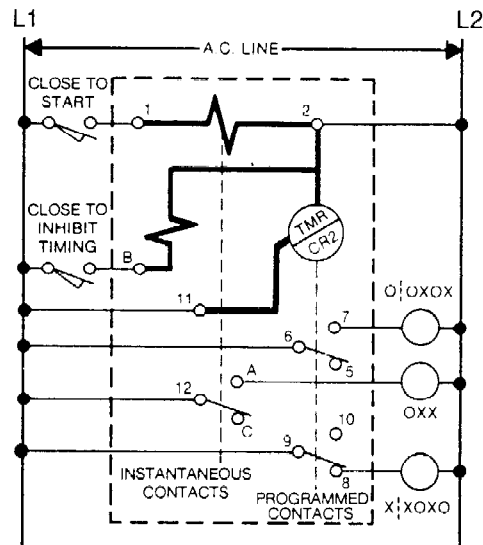

OFF Time First - Close control switch to begin timing cycle. Programmed contacts transfer after the off timing period.

## CX WIRING AND INSTALLATION PROCEDURES

1. Install the resistor capacitor suppressor, Eagle part number PBN2002 between terminals 2 and 11. A PBN2002 resistor capacitor suppressor (Quencharc) kit is shipped with every CX.
2. After wiring is complete, power should be applied constantly to terminal 11. The CX should be started and reset by closing and opening switch to Terminal 1 only. This meets the requirements of having power to terminal 11 at least 300 milliseconds before power is applied to terminal 1.
3. In electrically noisy environments, it may be necessary to suppress the loads. Most commonly, electrical noise can be traced to the inductive loads in the control circuit. It is especially important to quench inductive loads turned ON and OFF by the CX. A quencharc (Part Number PBN2002) should be placed in parallel with the load. This should be done at the load but can be done by wiring a quencharc between terminal 2 and the switching contact.
4. The CX should be well grounded to the enclosure and the enclosure should be on a good factory ground. The CX's housing lower mounting hole is used as a ground connection. (See Mounting Dimension section in this bulletin.)
5. Do not bundle AC wires. Do not bundle input wiring lines to terminal 1, 11, and 2 with relay output wiring. Do not bundle AC wires with DC input wires.
6. Any large components such as motor starter contactors that emit EMI should be located a couple of feet away from the CX.

## MOUNTING DIMENSIONS

XX = INCHES  
(XX) = MILLIMETERS

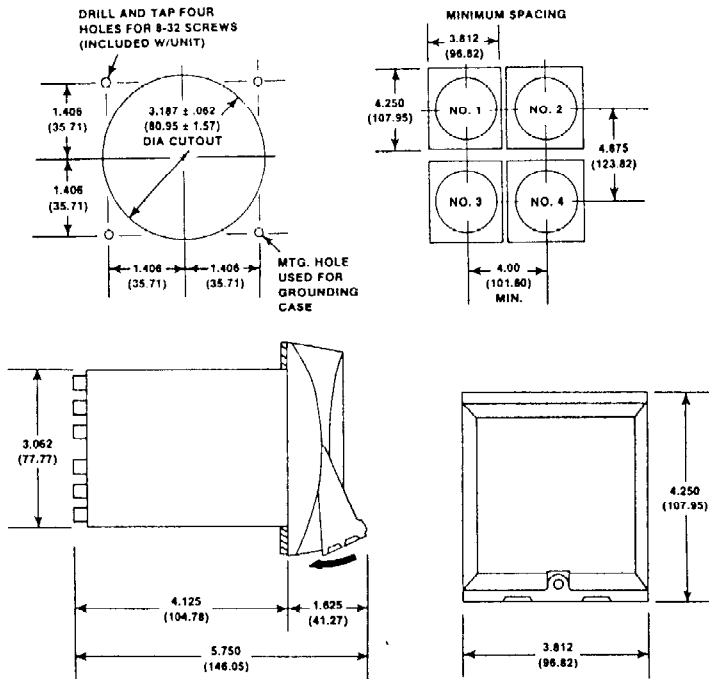

## ENCLOSURES

PART NUMBER	NEMA CLASS	DESCRIPTION
HN308	1	Surface Mtg. with terminal block
HN364	1	Surface Mtg. without terminal block
HN370	1A	Dual unit cabinet less unit cases and toggle switch, with 9 terminal block.

## ACCESSORIES

PART NUMBER	DESCRIPTION
H-5331	Mounting Brackets 2 req'd per timer
HP50-31	One Hole Mounting Ring
HP50-131	CYCL-FLEX Water - Sealed Housing Provides NEMA 4 Hosedown rating for CX Series Timer/Counters
HP50-133	Surface Mounting Adapter to use in place of Brackets

## ORDERING INFORMATION

