

**CX200 SERIES
MICROPROCESSOR BASED
SOLID STATE TIMER/COUNTER**

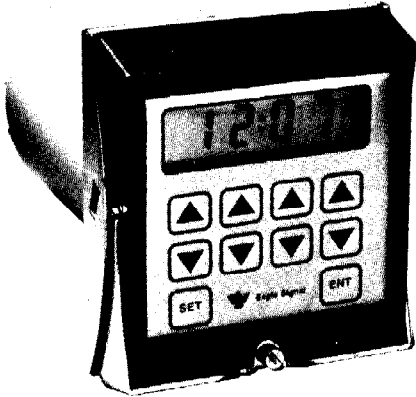

6
ELECTRONIC
TIMERS

The CX200 is a microprocessor based timer/counter housed in a standard 15 terminal CYCL-FLEX® plug-in case. Time or count operation, time range, and standard or reverse start operation is selected by 7 miniature rocker switches located inside the unit housing. Time or count setpoints are entered into the unit using a sealed membrane keypad on the front of the unit. Each digit in the setpoint is individually increased or decreased by pressing the appropriate keypad switch. Time or count setpoint and progress is displayed on the front of the unit by a 4½ digit liquid crystal display with .5 inch digits. Operational mode annunciators also appear in the display area on the front of the unit. The mode annunciator flashes when the unit is timing or counting.

Five time ranges from 19.999 seconds to 199 hrs; 59 min, and two count rates are available. Each count rate will accept and display counts from 1 to 19999.

The CX200 timer/counter has two relay outputs; two form C instantaneous contacts, and two form C programmed contacts. The relays are socket mounted for easy replacement. The CX240 configuration has one N.O. solid state MOSFET, delayed action switch rated at 1 ampere continuous load current, 0-264 VAC 50/60 Hz or DC. The MOSFET output has an ON resistance of 0.5 ohm, and a very low OFF leakage, making the output ideal for switching low level signals as well as high voltage loads. The programmed outputs can be programmed to operate in one of four load sequences; OOX, OXO, OOX with pulse output, and OOX pulse output with repeat cycle operation.

Standard start is defined as an ON delay reset timer or counter. On standard start units, the timer/counter resets on power failure. Reverse start or OFF delay units will not reset on power failure, and will continue the cycle when power is restored.

SPECIFICATIONS

Time/Count Range

SYM.	MAXIMUM RANGE	MINIMUM SETTING	COUNT RATE
1	19999 Cts	1 Count	500/Min AC
2	19999Cts	1 Count	5000/Min AC
3	199.99 Sec	.01 Sec	
4	1999.9 Sec	.1 Sec	
5	19.999 Sec	0.001 Sec	
6	199 Min:59 Sec	1 Sec	
7	199 Hr:59 Min	1 Min	

Time Inhibit/Count Line Voltage & Frequency

SYMBOL	VOLTAGE & FREQUENCY
A6	120 VAC 50/60 Hz
B6	240 VAC 50/60 Hz
K6	208 VAC 50/60 Hz

Setting Accuracy

Count — 100%
Time — ± 0.1% or 50ms, whichever is larger (0° to 60°C)

Repeat Accuracy

Count — 100%
Time — + .001% or 35ms, whichever is larger (0° to 60°C).

Reset Time

30 ms following voltage removal from simulated clutch input (CR1).

Operating Temperature

+32° to +140°F (0° to 60°C)

Operating Voltage/Frequency

SYMBOL	VOLTAGE & FREQUENCY
A6	120 VAC 50/60 Hz
B6	240 VAC 50/60 Hz
K6	208 VAC 50/60 Hz

Output Rating

Relay - 10 Amp (resistive) 120 VAC
Mechanical Life - 20 million operations
Electrical Life - contingent upon controlled load
Solid State - 1 amp, 0-264 VAC, VDC

Vibration

Unit function is unaffected by 2.5G sinusoidal vibration magnitude in both directions of the perpendicular mounting axes imposed from 10 to 100 Hz.

Static Discharge

Unit operation unaffected by a constant 3600 volt peak, 60 Hz discharge applied to the grounded front plate of the unit at a relative humidity of less than 25%.

Battery Life

The CX uses a lithium battery with an expected life of 10 years.

Power On Response Time

300 ms maximum after voltage applied to terminal 11.

Laboratory Testing

U.L. Recognition E96337
C.S.A. Certification LR26861



OPERATION

Programming Procedure

A series of 7 miniature rocker switches located inside the unit housing are used to program the time ranges and operating modes of the CX200 timer. The following table defines the switch conditions to program the operating parameters. **CAUTION: The product program label should always be marked to indicate the operating mode of the unit in case replacement is required.**

SYM	PROGRAMMED CONTACTS OUTPUT SEQUENCE	SWITCH NUMBER							Notes
		1	2	3	4	5	6	7	
1	OOX	X	X						
2	OXO	O	X						
3	OO [X] Pulse Output	X	O						c
4	OO [X] Repeat Cycle	O	O						c
TIME OR COUNT INPUT RANGE									
1	COUNT - 500/Min			O	X	X			a
2	COUNT - 5000/Min			X	O	X			a
3	TIME - .01 Sec			O	O	X			
4	TIME - 0.1 Sec			X	X	O			
5	TIME - 0.001 Sec			O	X	O			
6	TIME - Min/Sec			X	O	O			
7	TIME - Hrs/Min			O	O	O			
BATTERY									
1	Battery ON						X		b
2	Battery OFF						O		b
START MODE									
	Standard Start							O	
	Reverse Start							X	

X - Switch ON O - Switch OFF Blank = Don't Care

NOTES:

- When programmed for count range 1 or 2, counts are registered when voltage is removed (trailing edge) from count line. Range 1 should be used whenever possible to provide the best protection from contact bounce of the count source.
- Battery should be switched off for storage or shipment. Battery should be switched on for proper operation of CX200 unit. Turn the battery off to erase the memory and to reset the unit.
- Pulse is approximately 70 milliseconds (.07 seconds).

Entering and Displaying Setpoints

Whenever the CX200 unit is powered up and the previous setpoint has been lost, the digit display indicates four hyphens. The unit will not operate until it has been provided with a setpoint, clearing the display of hyphens.

To create or change a setpoint, press the **SET** key. The setpoint, if any, is displayed and the panel key pads become active. The operation of the timing or counting function and the output loads are not affected. For setpoint changes, the SE1 indicator appears on the graphics panel. The setpoint is changed by pressing appropriate Δ or ∇ key pads. Pressing a Δ key increments the setpoint digit located above the key; the ∇ key decrements the digit located above the key. If the pad is continually

depressed the digit will change every .5 second until the pad is released. The display will carry to the digit on the left on the 9 to 0 transitions when using the Δ pads. The display will borrow from the digits on the left on the 0 to 9 transitions when using the ∇ pads. On ranges 6 and 7, the display will carry on the 59 to 00 transition and borrow on the 00 to 59 transition of the two least significant digits.

When the desired setpoint is displayed, touch the **ENT** key. The new setpoint is entered, all Δ and ∇ keys become inoperable and "SET" disappears from the graphics panel. New setpoints can be entered while the unit is timing or counting, but they will not take effect until the next reset.

The setpoint may be displayed at any time without disturbing the timing or counting cycle by pressing **SET**. The actual value is returned by pressing **ENT**. If the unit is set at 0000, the load is always ON if programmed for OOX, and always OFF if programmed OXO.

A keypad "lock" is provided on the CX200 Timer/Counter to prevent unauthorized tampering. To initiate the keypad lock, press the word "SIGNAL" in the Eagle Signal logo for 8 seconds. To disable the lock to change setpoints, remove power from the unit and turn the battery off and then on. The unit will lose all setpoints and they must be re-entered for further operation.

CX200 TERMINAL ASSIGNMENTS

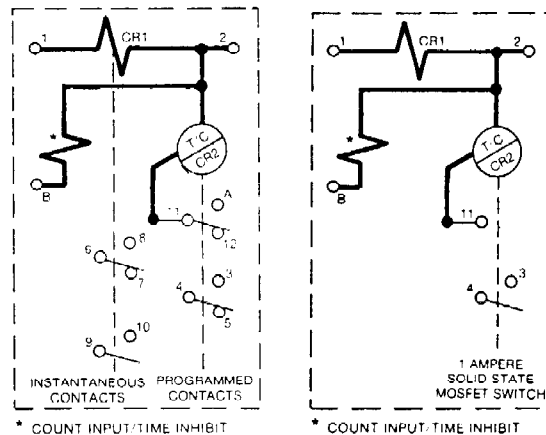

TERMINALS AND WIRING DIAGRAM ON REAR OF TIMER CASE

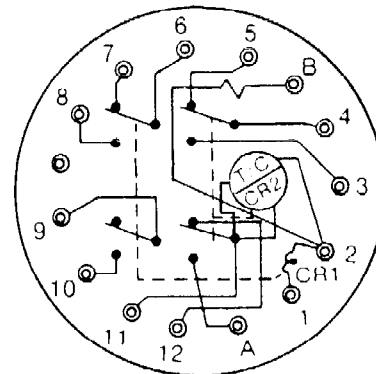

WIRING DIAGRAMS

Bold Lines are Internal Wiring

Power to unit is applied to terminal 11 and 2. The unit is started by applying power to terminals 1 and 2. **Power must be applied to terminal 11 at least 300 milliseconds before power is applied to terminal 1.** An isolated input is provided on terminal B which functions as a count input when the unit is used as a counter or as a time inhibit input when the unit is programmed to operate as a timer. Two sets of instantaneous contacts are provided which transfer whenever terminal 1 is energized. In addition, two sets of programmed contacts are provided. When programmed for Reverse Start, the unit will start when voltage is removed from terminal 1.

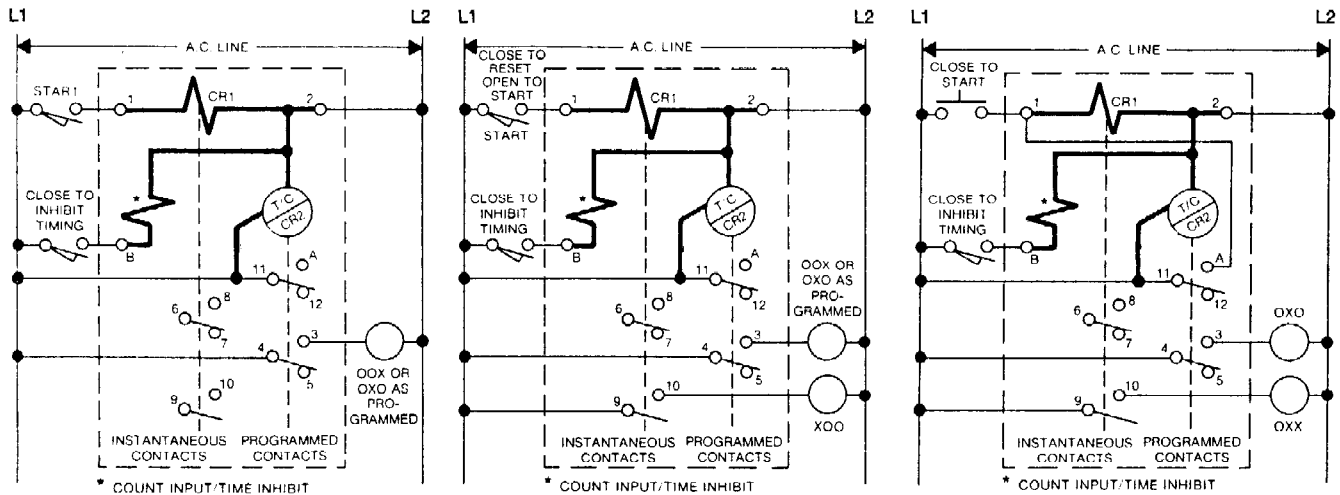

Standard Start — Close start switch to time; open to reset. Cycle progress is stopped without reset by closing inhibit switch. Unit resets on power failure. Setpoint is maintained by battery. Instantaneous contacts actuate with start switch. The programmed contacts actuate as programmed by rocker switches 3-5.

Reverse Start — Open switch to time; close to reset. Cycle progress is stopped without reset by closing inhibit switch. Unit does not reset on power failure. Battery retains cycle progress and setpoint.

Momentary Start — Close to time. Automatic reset at end of timing period. (Programmed for OXO output ONLY).

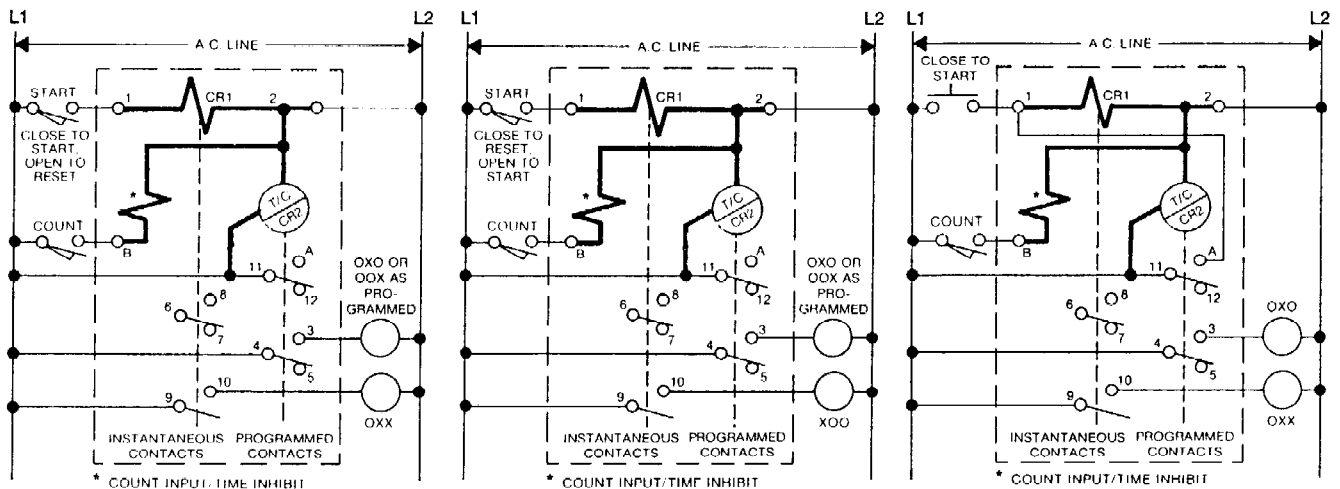

Standard Start — Close start switch to start, open to reset. Counts are registered when count switch opens. Unit resets on power failure. Setpoint is maintained.

Reverse Start — Close start switch to reset, open to start. Unit does not reset on power failure. Battery retains cycle progress and setpoint.

Momentary Start — Close to count. Automatic reset at end of counting period. (Programmed for OXO output ONLY).

WIRING DIAGRAMS — Solid-State Output Bold Lines are Internal Wiring

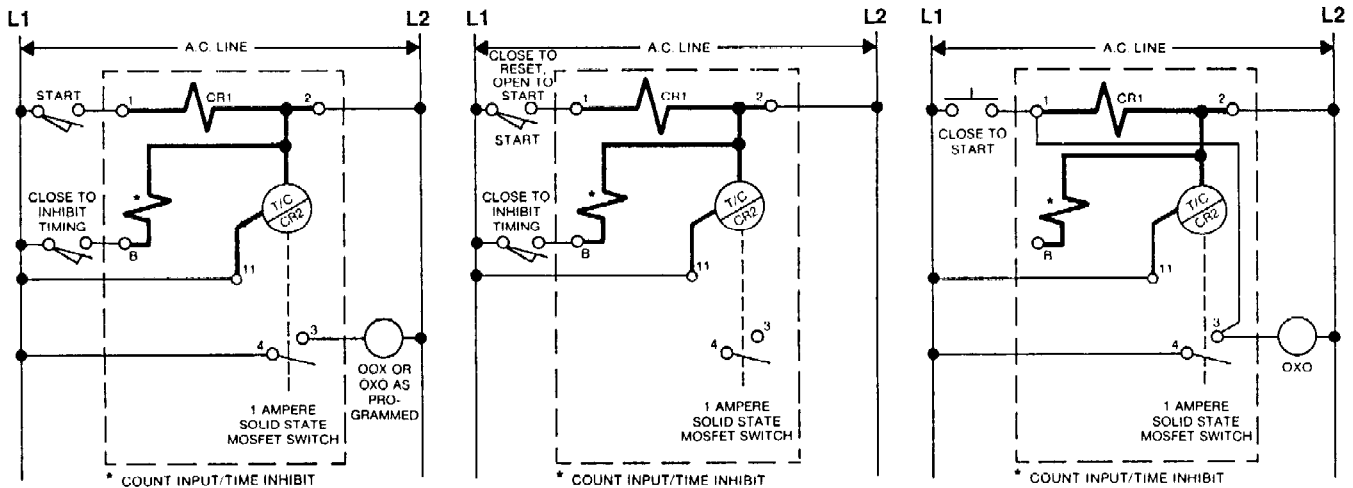

Standard Start — Close start switch to time; open to reset. Cycle progress is stopped without reset by closing inhibit switch. Unit resets on power failure. Setpoint is maintained by battery. Solid state delay contact actuates as interval (OXO) or delay (OOX) sequence as programmed by rocker switches.

Reverse Start — Open switch to time; close to reset. Cycle progress is stopped without reset by closing inhibit switch. Unit does not reset on power failure. Battery retains cycle progress and setpoint

Momentary or Sustained Start — Close to time. Automatic reset at end of timing period with start switch open or closed. (Programmed for OXO output ONLY.)

CX WIRING AND INSTALLATION PROCEDURES

1. Install the resistor capacitor suppressor, Eagle part number PBN2002 between terminals 2 and 11. A PBN2002 resistor capacitor suppressor (Quencharc) kit is shipped with every CX.
2. After wiring is complete, power should be applied constantly to terminal 11. The CX should be started and reset by closing and opening switch to Terminal 1 only. This meets the requirements of having power to terminal 11 at least 300 milliseconds before power is applied to terminal 1.
3. In electrically noisy environments, it may be necessary to suppress the loads. Most commonly, electrical noise can be traced to the inductive loads in the control circuit. It is especially important to quench inductive loads turned ON and OFF by the CX. A quencharc (Part Number PBN2002) should be placed in parallel with the load. This should be done at the load but can be done by wiring a quencharc between terminal 2 and the switching contact.
4. The CX should be well grounded to the enclosure and the enclosure should be on a good factory ground. The CX's housing lower mounting hole is used as a ground connection. (See Mounting Dimension section in this bulletin.)
5. Do not bundle AC wires. Do not bundle input wiring lines to terminal 1, 11, and 2 with relay output wiring. Do not bundle AC wires with DC input wires.
6. Any large components such as motor starter contactors that emit EMI should be located a couple of feet away from the CX.

ENCLOSURES

PART NUMBER	NEMA CLASS	DESCRIPTION
HN308	1	Surface Mtg. with terminal block
HN364	1	Surface Mtg. without terminal block
HN370	1A	Dual unit cabinet less unit cases and toggle switch, with 9 terminal block.

ACCESSORIES

PART NUMBER	DESCRIPTION
H-5331	Mounting Brackets 2 req'd per timer
HP50-31	One Hole Mounting Ring
HP50-131	CYCL-FLEX Water - Sealed Housing Provides NEMA 4 Hosedown rating for CX Series Timer/Counters
HP50-133	Surface Mounting Adapter to use in place of Brackets
PDM-534	1/4 DIN Adapter Plate

MOUNTING DIMENSIONS

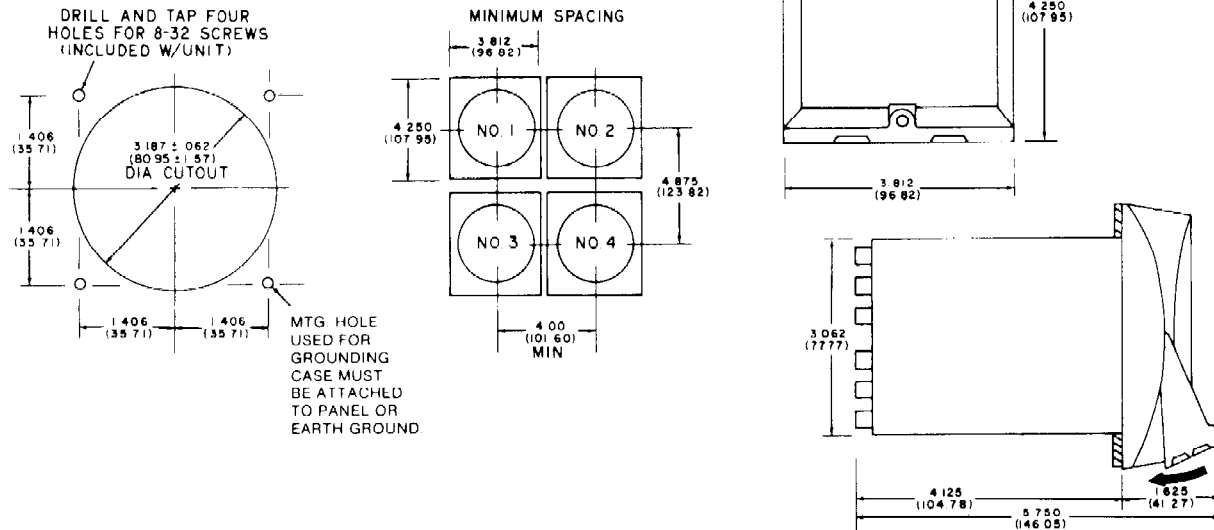

ORDERING INFORMATION

