

SPECIFICATIONS

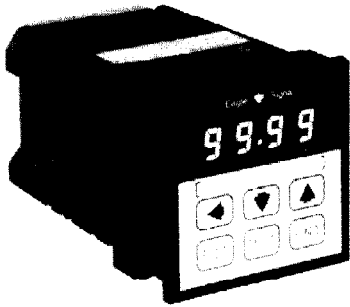

Time Ranges

SYM.	MAXIMUM RANGE	MINIMUM SETTING
1	99.99 Sec	.01 Sec
2	999.9 Sec	1 Sec.
3	99 Min:59 Sec	1 Sec.
4	99 Hr:59 Min	1 Min

Batch Counter Range

1-9999 or continuous

Setting Accuracy

Time: $\pm 0.05\%$ of setting or 50ms, whichever is greater
Count: 100%

Repeat Accuracy

Time: $\pm 0.001\%$ of setting or 35ms, whichever is greater
Count: 100%

Power On Response

200 milliseconds maximum

Reset Time

15 milliseconds

Operating Temperature

+32° to +122°F (0° to 50°C)

Operating Voltage/Frequency

SYMBOL	VOLTAGE & FREQUENCY
A6	120 VAC 50/60 Hz
B6	240 VAC 50/60 Hz

Sensor Power Supply

+12 VDC, 75 milliamps

Output Rating

Relay: 5 Amp (resistive), 10 to 264 VAC

Vibration

Unit function is unaffected by 2.5g sinusoidal vibration magnitude in both directions of the perpendicular mounting axes imposed from 10 to 100 Hz.

Static Discharge

Unit function is unaffected by a constant 3600 volt peak, 60 Hz discharge applied to the grounded front plate at a relative humidity of less than 25%.

Transient Protection

Immune to 2500 volts peak transients up to 50 microseconds in duration.

The **SX110** is a microprocessor based control that combines a three-setpoint repeat cycle timer with an internal batch counter. The three setpoints on the repeat cycle timer function allows overlap or dwell between the two output timing intervals. The batch counter counts the number of repeat cycle operations that the timer performs, and automatically stops the timer operation after the user programmed number of cycles.

The repeat cycle timer can operate as either a DPDT relay output with ON and OFF times, or as two independent SPDT relay interval outputs. When operated as two interval outputs, a third setpoint is available that can provide overlap of the two intervals or a dwell period between the two intervals. The time ranges for the output sequences are individually programmable. There are four time ranges available for each output sequence from 99.99 seconds to 99 hours:59 minutes.

The internal batch counter counts the number of cycles of the repeat timer output. The batch counter will also automatically stop the timing operation after the programmed number of cycles. The batch counter can be set to allow from 1 to 9999 cycles, or it can be set to provide continuous repeat cycle operation.

The **SX110** is housed in a standard DIN case (68mm square cutout). The case and front bezel require minimal panel space, yet provide easy to use programming keys and an easy to read .36 inch LED display.

The operating modes and time ranges for the unit are programmed using rocker switches on the back of the unit. This programming method provides both simplicity and security. The front panel display has a prompted programming routine that prompts the user when to program the ON and OFF times as well as the batch counter setpoint.

Some of the other features of the **SX110** Timer include:

- NEMA 4 Hosedown Test rated.
- Two 5 Amp SPDT relay outputs.
- Four output operating modes.
- Four independently programmable time ranges for the ON and OFF times.
- Time inhibit input.
- LED indicators for output status.
- Setpoint to zero or zero to setpoint cycle progress indication.

CONTROL INPUT FEATURES

The SX110 Timer uses all line voltage control inputs for high noise immunity.

The start input enables the timer and batch counter and initiates the programmed output sequences. This allows the timer operation to be started independently of when power is applied to the unit. This input will respond to sustained or momentary inputs.

When power is applied to the inhibit input, the time cycle stops and the outputs are held in their last state. The inhibit condition will continue as long as power is applied to the inhibit input or until the unit is reset.

When power is applied to the reset input, the timer and batch counter reset and the outputs are de-energized. The reset and output de-energized state will continue as long as power is applied to the reset input. A front panel reset key is also provided for manual reset operation. The front panel reset key can be disabled using the keypad lock function.

All inputs are optically isolated and respond in 15 milliseconds or less.

A 12 VDC, 75 milliamp power supply is provided for user convenience, although the SX110 timer uses line voltage inputs.

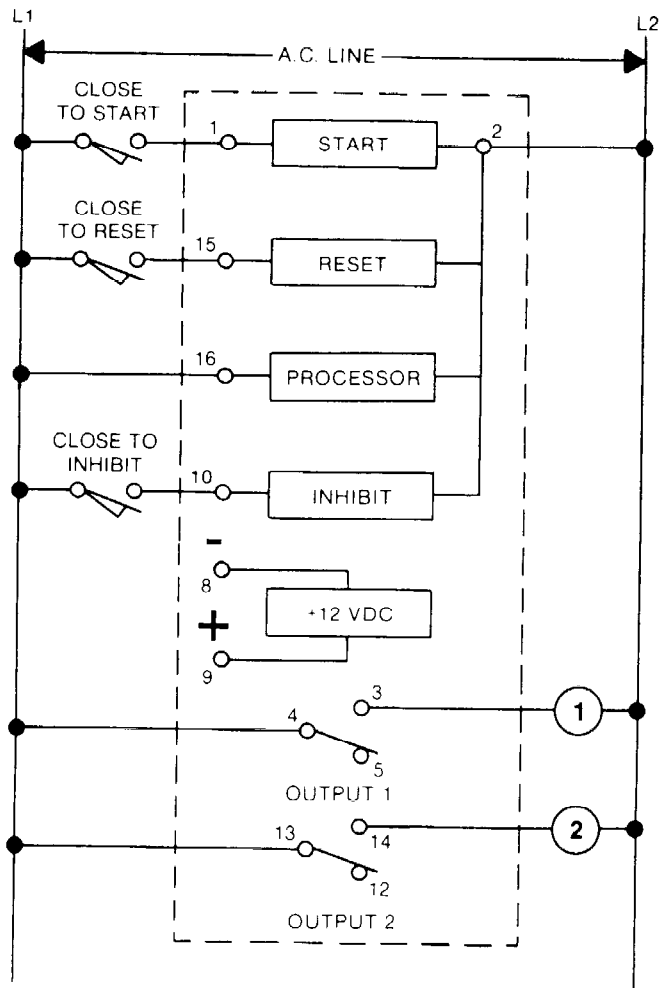

OUTPUT OPERATING MODES

Both relay outputs provide repeat cycle timing operation. In two of the modes the SPDT relays operate together to provide a DPDT relay output. In the other two modes the SPDT relay outputs provide independent timing intervals. These intervals can be made to either have an overlap or dwell between them by using the third setpoint.

1. DPDT - OFF Time First — Both outputs are energized together. The OFF time defined by Setpoint 1 (SET1) occurs first.

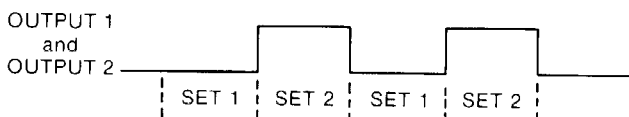

2. DPDT - ON Time First — Both outputs are energized together. The ON time defined by Setpoint 1 (SET1) occurs first.

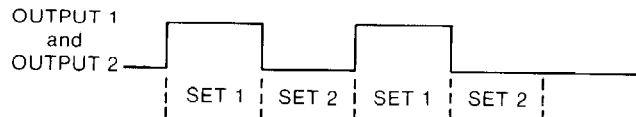

3. Overlapping Intervals — Output 1 is ON first. Output 2 is normally energized at the end of the Output 1 timing interval. The Output 2 timing interval can be programmed to begin before the end of the Output 1 interval by using Setpoint 3 (SET3). Setpoint 3 is the amount of time before the end of the Output 1 interval that the Output 2 interval is started. In repeat operation Output 1 is energized again at the end of the Output 2 interval.

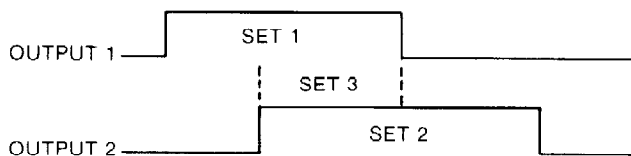

4. Non-Overlapping Intervals — Output 1 is ON first. Output 2 is normally energized at the end of the Output 1 timing interval. The Output 2 timing interval can be programmed to begin a delay or dwell period after the end of the Output 1 interval by using Setpoint 3 (SET3). Setpoint 3 is the amount of time after the end of the Output 1 interval that the Output 2 interval is started. In repeat operation the Setpoint 3 dwell period also occurs after the Output 2 interval, and before the Output 1 interval repeats.

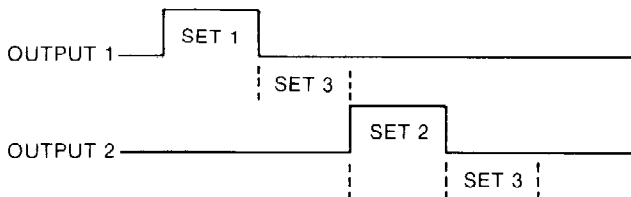

BATCH COUNTER OPERATION

The internal batch counter counts the number of actuations of Output 2. The batch counter can be programmed to provide a fixed number of repeat cycle operations from 1 to 9999. If the batch counter is set to 0000, the repeat timer operation will continue until the unit is reset.

RESET OPERATION

The SX110 Timer is programmable to either reset on power interruption and start over when power is reapplied, or to retain its actual cycle progress value and continue with the cycle when power is reapplied. The reset operation applies to both the timing function and the batch counter. This operation is determined with a switch setting on the back of the unit.

CYCLE PROGRESS INDICATION

The time progress display can be programmed either to cycle DOWN from the setpoint to zero or to cycle UP from zero to the setpoint. This operation is programmed through the front panel, and can be changed while the unit is operating.

START INPUT OPERATION

The SX110 Timer uses line voltage applied to terminals 1 and 2 to initiate the timing cycle. The start signal can either be a sustained voltage input or a momentary voltage pulse. When the sustained start input mode is used, removal of power from terminals 1 and 2 will stop the timing cycle. When the momentary start pulse mode is used, the timing cycle is initiated by the voltage pulse, and the timing cycle continues even if the signal is removed. The timer and batch counter can be reset either by using the front panel reset (RST) key, or by applying a reset signal on terminal 15. The operation of the start input is determined with a switch setting on the back of the unit.

FRONT PANEL PROGRAMMING

The SX110 Timer uses a sealed front panel keypad for entry of the ON and OFF time and the batch counter setpoints.

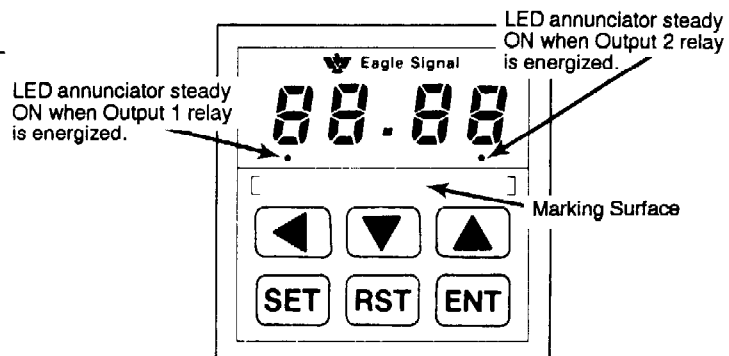

Pressing the SET key calls the prompted programming routine for the three setpoints. These are indicated with the "SET1", "SET2" and "SET3" prompts. Each setpoint is displayed with the least significant digit flashing. The position of the flashing digit can be changed using the ◀ key. The ▲ and ▼ keys increment and decrement the value of the flashing digit. The ENT key enters any setpoint changes into memory.

A keypad lock function is provided for security. Pressing and holding the ENT key for about five seconds will alternately lock and unlock the front keypad. When locked, the SET key will call the three setpoints, but the ▲, ▼, and RST keys will be inoperative.

The RST key is a manual reset. Pressing the RST key resets the timer and holds the outputs in their normal, deenergized states until the key is released. The front panel reset key can be disabled using the keypad lock function.

SWITCH PROGRAMMING

The SX110 Timer uses eight miniature rocker switches on the back of the unit to program the operating modes as follows:

X = Switch ON O = Switch OFF Blank = Does Not Apply

SYM.	OPERATING MODE	SWITCH NUMBER								
		1	2	3	4	5	6	7	8	
OUTPUT OPERATION										
1	DPDT - OFF Time First	O	O							
2	DPDT - ON Time First	X	O							
3	Overlapping Intervals	O	X							
4	Non-Overlapping Intervals	X	X							
SETPOINT 1 TIME RANGES										
1	99.99 Seconds			O	O					
2	999.9 Seconds			X	O					
3	99 Minutes:59 Seconds			O	X					
4	99 Hours:59 Minutes			X	X					
SETPOINT 2 TIME RANGES										
1	99.99 Seconds					O	O			
2	999.9 Seconds					X	O			
3	99 Minutes:59 Seconds					O	X			
4	99 Hours:59 Minutes					X	X			
RESET OPERATION										
1	Reset on Power Interruption								O	
2	Non-Reset on Power Interruption								X	
START OPERATION										
1	Sustained Start Input									O
2	Momentary Start Input									X

TERMINAL ASSIGNMENTS

The SX110 Timer uses two removable terminal blocks to provide wiring connections, with the following terminal assignments.

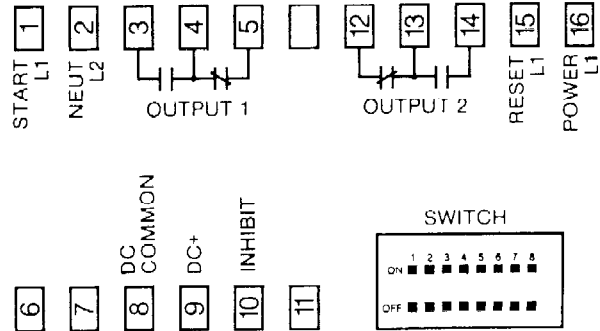

Terminals 6, 7, and 11 are not used on the SX110 timer.

For more information, refer to the SX110 Instruction Manual, publication number 5005-789.

MOUNTING

The SX110 Timer uses two removable mounting clips with adjustable screws to mount the enclosure in a panel as shown below.

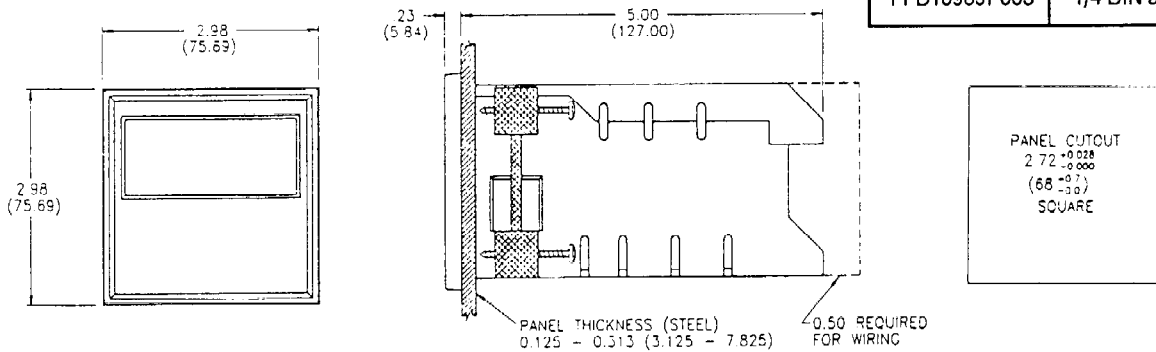

ORDERING INFORMATION

